



# AIR Control Display 57

## Pilot's Manual

Document: MAN0010A0001  
Version: 3.0  
Date: 2021/06/30



Please read this manual carefully before using the device.

Observe limitations and safety instructions.

This manual is an essential portion of the device and must be kept in a safe place.

## Articles Covered

This manual covers the following articles:

- ACD-57 "AIR Control Display 57"

## Revision History

<i>Rev.</i>	<i>Date</i>	<i>Status</i>	<i>Author</i>	<i>Changes</i>	<i>Approved</i>
1.0	2017/04/06	Release	M. Förderer	Initial release	J. Garrecht
1.1	2017/06/27	Release	H. Hoeth	Revised list of limitations	J. Garrecht
1.2	2017/08/25	Release	H. Hoeth	Inactivity timeout in menus Squelch on/off button for Becker radios Startup time of connected devices	J. Garrecht
1.3	2018/01/19	–	H. Hoeth	Preset VFR squawk softkey QNE softkey	
2.0	2018/03/29	Release	H. Hoeth	Update manual for SW version 0.42: Explain new features Update softkey menu diagram Emphasize 8.33 channel selection Clarify transponder mode selection	J. Garrecht
2.1	2018/07/12	Release	H. Hoeth	Added trouble shooting chapter Clarify "channel spacing" setting	J. Garrecht
3.0	2021/06/30	Release	H. Hoeth	Updated manual for SW version 0.44: Added AIR COM related information Added TRIG TY9x as compatible device Changes to intercom settings menu Improved channel selection behaviour	J. Garrecht

## Product Support

If you have questions, our product support team will be happy to help you. Contact us via [support@air-avionics.com](mailto:support@air-avionics.com) or by phone. Please find details about our hotlines and availability online at <https://www.air-avionics.com>

# Contents

## Getting Started · 1

Introduction · 1

Limitations and Safety Instructions · 2

Pilot Controls · 4

General Considerations · 7

Switching On and Off · 9

## COM Operation · 10

Introduction · 10

Audio Control · 11

Selecting a COM Channel · 14

Nearest and History Functions · 14

Channel Memory · 16

RX/TX Indication and Stuck PTT Function · 19

Say Again Function · 20

## XPDR Operation · 22

Introduction · 22

Selecting a Squawk Code · 23

Using the Ident Function · 23

Changing XPDR Mode · 24

## Altimeter Operation · 27

Altimeter User Interface · 27

Adjusting Barometric Reference · 27

Altitude Display Unit · 28

## Combined Functions · 29

COM, Transponder, and Altimeter Combined · 29

COM and XPDR Combined · 30

COM and Altimeter Combined · 30

XPDR and Altimeter Combined · 31

<b>System Configuration</b>	<b>· 32</b>
Configuration Operations	· 32
Device Configuration	· 32
Altimeter Configuration	· 34
ACD-57 COM Control Configuration	· 35
Connected COM System Configuration	· 38
ACD-57 XPDR Control Configuration	· 39
Connected XPDR System Configuration	· 40
<b>Software and Station Database Updates</b>	<b>· 41</b>
Version Identification	· 41
Software/Database Loading	· 41
<b>Failures and Abnormal Operation</b>	<b>· 44</b>
Failures	· 44
Insufficient Data Failure Modes	· 44
Systems Failures	· 45
<b>Troubleshooting</b>	<b>· 47</b>
I am unable to tune in 8.33 kHz channels	· 47
I am unable to tune in 25 kHz frequencies	· 47
<b>Configuration Menu Diagram</b>	<b>· 48</b>
<b>Softkey Menu Diagram</b>	<b>· 50</b>
COM Control Only Softkeys	· 50
XPDR Control Only Softkeys	· 51
Altimeter Only Softkeys	· 51
COM and XPDR Control Softkeys	· 52
COM and Altimeter Control Softkeys	· 53
XPDR Control and Altimeter Softkeys	· 54
COM, XPDR Control, and Altimeter Softkeys	· 55
<b>Quick Reference List</b>	<b>· 56</b>
Switch On or Off	· 56
COM Operation	· 56
XPDR Operation	· 57
Altimeter Operation	· 57



## 1.1 Introduction

ACD-57 is a small multi-function control display intended for controlling ATC radar beacon systems (transponder, XPDR) and airborne VHF transceivers (COM). Furthermore the system is capable of determining and displaying a precise pressure altitude (altimeter). The system is connected to transponder and COM devices using standardized interfaces.

The small outline and multifunctional software of the device allow for better system integration in space constrained environments. The pilot-centered user interface aims at reducing crew workload, increasing crew efficiency and improving flight safety.

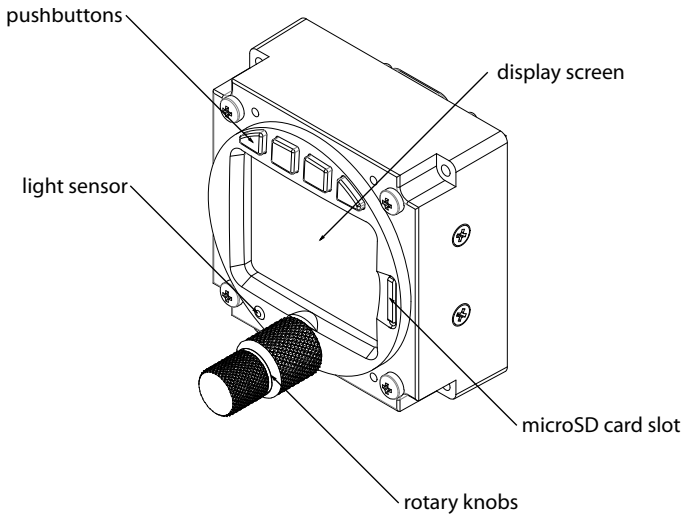

Figure 1.1.: ACD-57 front panel overview

## 1.2 Limitations and Safety Instructions

### 1.2.1 Safety

ACD-57 shall never distract from general practices of safe airmanship. Using ACD-57 may impose significant workload on the flight crew if not adequately familiar with ACD-57 and trained on its operation. In order to use ACD-57 effectively, familiarization with the unit is essential.

We recommend a thorough study of this manual and extensive familiarization on ground.

Do not fly with ACD-57 if you are unfamiliar with its operation and limitations

Installations in which ACD-57 devices are used may be complex. Familiarization of specific installation conditions in an aircraft, for example the number, type, and configuration of connected systems is essential before using ACD-57.

ACD-57 installation requires several forms such as checkout forms and configuration logs to be filled out by installation personell. These documents are stored in the aircraft's documentation and are a viable resource for pilots who wish to study installation specifics of an ACD-57 in an aircraft.

### 1.2.2 Regulatory Requirements

It is the responsibility of those using this article to determine that the installation and working conditions are within required standards.

Independently from ETSO authorizations, depending on aircraft type and certification base, ACD-57 may not be suitable as a primary altimeter, COM control, or XPDR control unit.

### 1.2.3 Screen Shots

All screen shots used in this document are current at the time of publication.

Screen shots are intended to provide visual reference only. All information depicted in screen shots, including software file names, versions, and part numbers, is subject to change and may not be up to date.

### 1.2.4 Function Licensing and Database Expiry

Certain functionality is subject to a software licensing model and has to be unlocked during installation. This manual assumes that all required licenses have been installed during installation. Details can be found in the ACD-57 Installation Manual [?].

Some software features such as databases have expiration dates and may become unavailable as they expire. Validity is checked regularly. After the underlying database has expired, some functions may become unusable.



### 1.2.5 Liability

IN NO EVENT WILL AIR AVIONICS BE LIABLE FOR ANY INCIDENTAL, SPECIAL, INDIRECT OR CONSEQUENTIAL DAMAGES, WHETHER RESULTING FROM THE USE, MISUSE OR INABILITY TO USE THE PRODUCT OR FROM DEFECTS IN THE PRODUCT.

### 1.2.6 Limitations

#### 1.2.7 Low Temperature Operations

If the temperature is below  $-10^{\circ}\text{C}$ , the ACD-57 must be powered on at least 5 minutes before flight, in order to warm up the display.

## 1.3 Pilot Controls

Inner and outer knobs have 16 detents per revolution and can be rotated clockwise and counter-clockwise. The inner knob has a pushbutton. Four softkey pushbuttons are located on the bezel along the top of the TFT display screen.

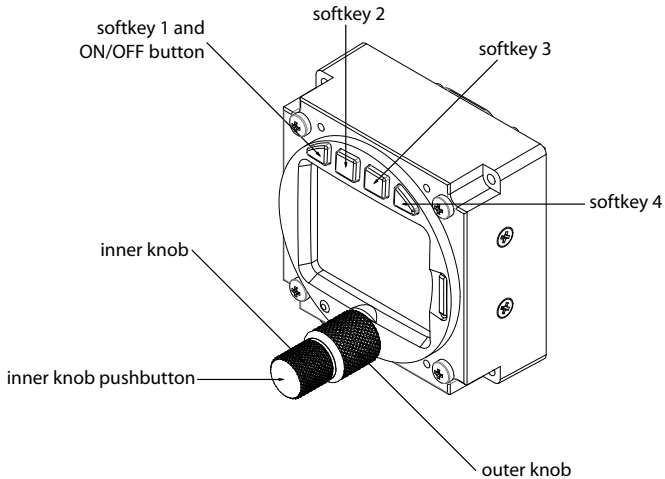

Figure 1.2.: ACD-57 pilot controls

### 1.3.1 Inner Knob Functions

- In the menu, the **(inner knob)** controls the position of the menu focus.
- On the main page, the **(inner knob)** opens the volume control page if a VHF transceiver is controlled.
- If only a Mode-S transponder system is controlled (and no VHF transceiver), on the main page, the **(inner knob)** opens the XPDR page.
- If only altimeter functions are used (and no VHF transceiver or XPDR is controlled), on the main page, the **(inner knob)** opens the barometric reference selection page.
- On the COM channel selection page, the **(inner knob)** adjusts kHz in the smallest increments<sup>1</sup>. To move in 25 kHz steps, push and turn the **(inner knob)**.
- On the volume control page, the **(inner knob)** controls the ACTIVE channel volume.
- On text input pages, the **(inner knob)** controls the text character.

<sup>1</sup>Steps can be setup to 8.33 kHz channels and 25 kHz frequencies and 8.33 kHz or 25 kHz only

### 1.3.2 Inner Knob Pushbutton Functions

- On the main page, the **inner knob pushbutton** is used to toggle ACTIVE and STANDBY channels of a connected COM unit (short push) and for opening the menu (long push).
- In the Menu, the **inner knob pushbutton** is used for menu item execution/ENTER (short push), for toggling ON/OFF setting menu items (short push), or for closing the menu (long push).

### 1.3.3 Combined Inner Knob and Inner Knob Pushbutton Functions

By simultaneously pushing/holding the **inner knob pushbutton** and rotating the **inner knob**, special functions are controlled.

- On the COM channel memory page, stored channels can be sorted.
- On the COM channel selection page, frequencies are changed in 25 kHz steps. If the ACD-57 is set to 8.3kHz in the configuration menu, channels are changed in 25 kHz steps.

### 1.3.4 Outer Knob Functions

- In the menu, the **outer knob** controls the position of the menu focus as well.
- On the main page, the **outer knob** opens the volume control page if a VHF transceiver is controlled.
- If only a Mode-S transponder system is controlled (and no VHF transceiver), on the main page, the **outer knob** opens the XPDR page.
- If only altimeter functions are used (and no VHF transceiver or XPDR is controlled), on the main page, the **outer knob** opens the barometric reference selection page.
- On the volume control page, the **outer knob** controls the STANDBY channel volume.
- On the COM channel tuning page, the **outer knob** controls the channel (MHz).
- On text input pages, the **outer knob** controls the input position (cursor).

### 1.3.5 Inactivity Timeout

The user interface consists of several different screen views (pages). If on any page (other than the main page or the configuration menu) no user input occurred for more than 10 seconds, the ACD-57 automatically switches back to the main page.

### 1.3.6 Softkeys

Four “softkey” pushbuttons are located on the top of the front bezel of the device. The softkey designators on top of the TFT display screen show the softkey’s current function. Softkey functions change depending on menu level and context.

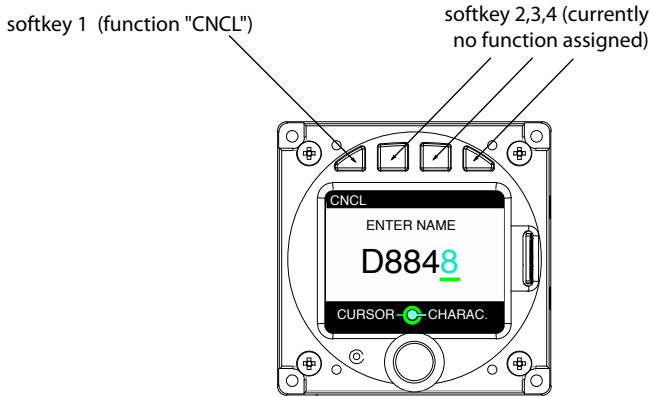

Figure 1.3.: Text input page. The leftmost softkey has a function (CNCL means cancel)

As an addition to its normal softkey functions, **softkey 1** can be used for switching ACD-57 on or off with a long push. This function has to be activated by setting a configuration parameter during installation (not the default configuration).

### 1.3.7 Display Color Coding

If visible, all functions the **outer knob** controls are kept in the color *green*, all functions the **inner knob** controls are kept in the color *cyan*.

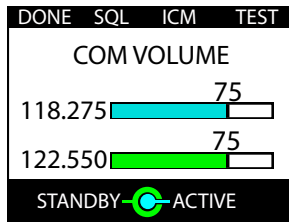

Figure 1.4.: COM volume control page. The **inner knob** always controls the cyan-colored elements, **outer knob** the green-colored elements.

### 1.3.8 Light Sensor

A sensor detecting ambient lighting conditions is placed on the left side of the concentric rotary knobs. User interface illumination, that is display backlight and softkey illumination, can be automatically adjusted using information from the light sensor. This function has to be activated by setting a configuration parameter during installation.

A filter is used to slow down changes in user interface illumination. This prevents the

illumination level from changing too quickly, for example when shadowing the sensor with your hands during operation of the knobs.

If the user interface illumination is controlled by the aircraft's lighting bus, the ACD-57 uses the light sensor for plausibility checks to prevent blinding the flight crew at night. If the light sensor detects low ambient lighting conditions, but the lighting bus is set to a high brightness, the ACD-57 issues a warning and switches into manual illumination override mode. Details on the illumination override mode can be found in the section "Illumination Override" on page 32.

## 1.4 General Considerations

### 1.4.1 User Interface and Softkeys

The ACD-57 system software is configurable and can be adapted to the requirements of an individual installation. For example it is capable of interfacing and controlling different COM and XPDR systems from various manufacturers and optionally displaying altitude functions. Hence the user interface, softkey structure, and configuration menu are flexible and dynamic.

This manual covers the operation of COM control, XPDR control, and altimeter separately. Yet these functions can also be combined. Chapter 5 shows user interfaces for all combinations possible.

Appendix B holds a diagram of all available softkeys depending on device configuration.

### 1.4.2 Limitations of Connected Devices

Please be aware that not all functions supported by ACD-57 may be supported by connected COM devices. Carefully observe limitations and functions of connected COM devices in order to assess system limitations that apply to your aircraft. The following table gives an overview on functions not supported by all connectable COM systems and other limitations thereof:

<i>Function</i>	<i>AIR COM VHF Transceiver</i>	<i>Becker 620X VHF Transceiver</i>	<i>Dittel/TQ KRT2 VHF Transceiver</i>	<i>TRIG TY91/TY92 VHF Transceiver</i>
Say Again Function	●	–	–	–
Standby COM channel independent volume level possible	●	–	–	–
VHF transceiver system configuration during installation	●	●	–	●
Interface speed from ACD-57 to VHF transceiver	fast (nearly in real time)	normal (sometimes delays are recognizable)	slow (up to half a second delay)	normal (sometimes delays are recognizable)

### 1.4.3 Connected Devices Parameter Changes

Whenever a parameter in an external system such as a COM or XPDR device is changed, ACD-57 sends a change request to the COM or XPDR device through a data interface. Information is only updated on the display screen of the ACD-57 if the change has been acknowledged and transferred back to ACD-57 by the COM or XPDR device.

Therefore a delay (normally less than half a second) can be visible, depending on the type of the connected device, the data interface, and the parameters changed.

Some elements of the user interface, for example on the volume control page, present the value the parameter shall be changed to and the current value active in the connected system.

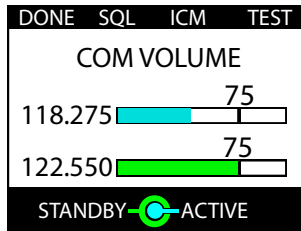

Figure 1.5.: Volume control page. The cyan colored bar indicates the value currently active in the connected COM unit, the little black pointer and numerical value show the value currently set in ACD-57. Normally this discrepancy disappears within half a second.

### 1.4.4 Connected Devices Startup Time

Some connected devices may need a significantly longer time than ACD-57 to power up. For example, a connected KRT-2 COM unit needs up to 20 seconds before it starts to send data to the ACD-57. While the ACD-57 is not yet receiving data from a connected system, the connected system's status is not known and therefore red crosses are shown on the parts of the display referring to the connected system.

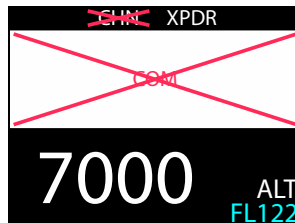

Figure 1.6.: No data from connected COM system after power up. This condition may last up to 30 seconds after power up.

## 1.5 Switching On and Off

### 1.5.1 Power On

By default the ACD-57 switches on automatically if sufficient supply power is present. ACD-57 switches on at 9V DC.

In order to switch ACD-57 on manually, *POWER ON MODE* can be deactivated in the *CONFIGURATION MENU*. For details, please consult the ACD-57 Installation Manual [?]. If *POWER ON MODE* is deactivated and if the ACD-57 has been manually switched off before, ACD-57 is powered on by pushing **softkey 1** for at least 0.5 seconds.

The boot phase of ACD-57 takes less than one second. No special boot screen is shown.

When turned on, ACD-57 powers up all connected avionics systems (such as COM or XPDR) if they have not been powered up already.

### 1.5.2 Power Off

If *POWER ON MODE* is active (default), ACD-57 is switched off by taking away power. ACD-57 switches off if the supply voltage drops below 8V DC. In this mode, ACD-57 can not be switched off manually using **softkey 1**.

If *POWER ON MODE* is deactivated, push **softkey 1** longer than 4 seconds to switch ACD-57 off.

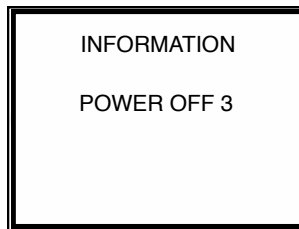

Figure 1.7.: Power off screen. The countdown timer on the right (here 3 seconds) counts down until the unit is switched off.

# 2

## COM Operation

### 2.1 Introduction

ACD-57 is capable of controlling a connected VHF transceiver (COM). ACD-57 can serve as primary means for control of a COM unit including COM unit setup, channel selection, and audio control.

Multiple ACD-57 can be installed on one COM unit and control the COM unit simultaneously. This is especially used in large aircraft or aircraft with tandem seating configurations.

#### 2.1.1 COM User Interface

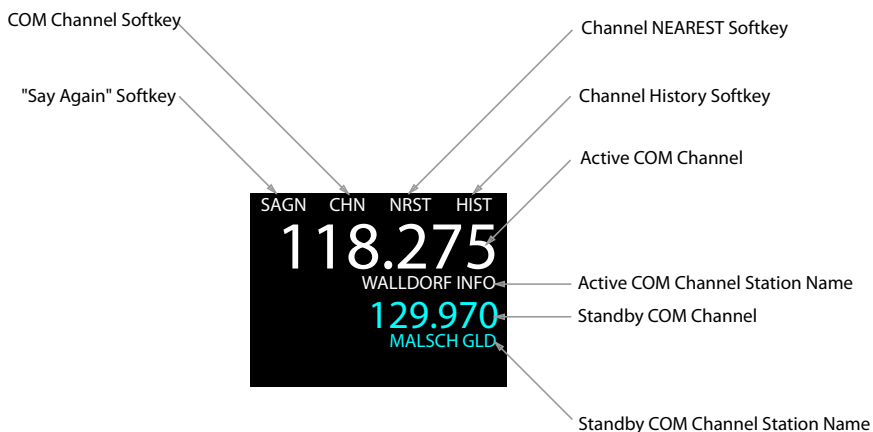

Figure 2.1.: COM user interface on main page explained.

ACTIVE and STANDBY channels are displayed on the main page.

Depending on configuration and database/position availability, channel names may be displayed on the main page. The name of the nearest station will be shown.

Station names are only shown for stations within a distance of approx. 20 miles from the aircraft's current position.



The display of station names in ACD-57 requires GPS position data from an external source that needs to be connected and configured during installation. Furthermore, a valid station database (microSD card) is required. If no GPS position data or no station database is present, the function is not available and station names are not shown.

## 2.2 Audio Control

### 2.2.1 Volume Control

To enter the volume control page, rotate the **inner knob** or the **outer knob** on the main page.

In the volume control page, you can use the **inner knob** to adjust ACTIVE channel volume. Use the **outer knob** to adjust STANDBY channel volume.

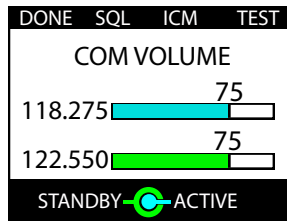

Figure 2.2.: Volume control page

If the connected COM unit does not support individual volumes for ACTIVE and STANDBY channel (Dittel/TQ KRT2 or Becker 620X), **outer knob** switches DUAL/SCAN mode on or off.

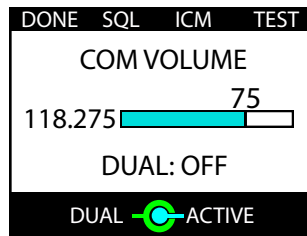

Figure 2.3.: Volume control page for KRT2 COM unit. **outer knob** switches DUAL mode on or off.

On the volume control page, as long as pushed the **TEST softkey** will open the squelch for some seconds in order to test the audio output. Testing the audio output before each flight is recommended.

If the *KNOB USE* parameter in the configuration menu is set to *CHANNEL*, rotating the knobs changes channels. To access the volume control page in this configuration, please push the (VOL softkey) on the main page. Details on the *KNOB USE* parameter can be found in the section “Knob Use” on page 36.

## 2.2.2 Monitoring the STANDBY COM Channel

The STANDBY COM channel monitoring function (also known as “DUAL WATCH” or “SCAN”) is always active, when the STANDBY channel volume is set to a value above zero. If set to zero, the STANDBY COM channel monitoring is deactivated.

Some COM units (currently only DITTEL/TQ KRT2) do not support individual values for the volume of the standby COM channel. If such a COM unit is used, the volume value for the standby COM channel is synced with the value for the active COM channel. In this case, rotating the (outer knob) only activates or deactivates standby COM channel monitoring entirely.

## 2.2.3 Squelch Level Control

The squelch level control page is accessed by pushing the (SQL softkey) on the volume control page. It is recommended to keep the squelch level at the lowest value required for filtering white noise.

If the connected COM system doesn't completely open the squelch at the “zero” setting (e.g. Becker radios), the squelch can be turned on and off with the (softkey 4).

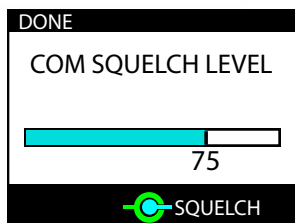

Figure 2.4.: Squelch control page

## 2.2.4 Intercom Control

The volume of the intercom function and the intercom VOX level can be individually configured for both intercom inputs. Intercom volume is the audio volume of the intercom audio output. Intercom VOX level is the sound level at which the intercom function is engaged / opened.

The intercom volume control page can be accessed by pushing the (ICM softkey) on the volume control page. Use the (inner knob) to adjust the intercom volume for input 1 and the (outer knob) to adjust the intercom volume for input 2.

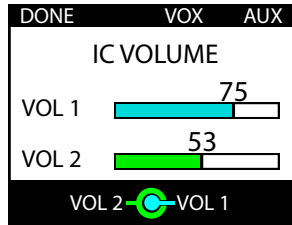

Figure 2.5.: Intercom volume control page

The intercom VOX level control page can be accessed by pushing the **VOX softkey** on the intercom volume control page. Use the **inner knob** to adjust the VOX level for input 1 and the **outer knob** to adjust the VOX level for input 2.

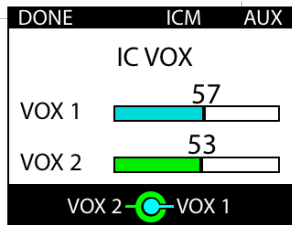

Figure 2.6.: VOX level control page

### 2.2.5 AUX Volume Control

A maximum of two AUX volumes can be individually adjusted. The aux inputs can, for example, be used to connect an audio player, mobile phone, or external avionics system to the connected COM unit. The number and logic behind the AUX inputs depends on the connected radio. Please familiarize yourself with the installation conditions before using the AUX inputs.

The aux input level control page can be accessed by pushing the **AUX softkey** on the intercom control page.

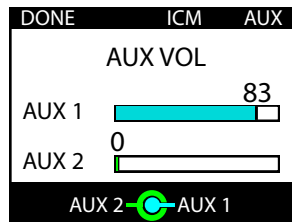

Figure 2.7.: Aux input level control page

## 2.3 Selecting a COM Channel

Channel selection always selects the STANDBY channel. In order to change the ACTIVE channel, the STANDBY and ACTIVE channel must be toggled.

### 2.3.1 Toggling STANDBY and ACTIVE Channel

To switch between ACTIVE and STANDBY COM channel (toggle), push the **inner knob pushbutton** on the main page.

### 2.3.2 Manual Channel Selection

To open the channel selection page, push the **CHN softkey**.

If the *KNOBUSE* parameter in the configuration menu is set to *CHANNEL*, you can rotate the **inner knob** or the **outer knob** on the main page to access the channel selection page. Details on this parameter can be found in the section "Knob Use" on page 36.



Figure 2.8.: Channel Selection Page

1. To open the channel selection page, push the **CHN softkey** on the main page.
2. To select a channel, use the **inner knob** for kHz selection and the **outer knob** for MHz selection. The **inner knob** tunes both 8.33 kHz and 25 kHz channels. For a quicker channel selection you can push the **inner knob pushbutton** and simultaneously turn the **inner knob**.
3. Push the **inner knob pushbutton** to execute the channel selection and to exit the channel selection page to the main page.

You can exit the selection process, discard the selection, and return to the main page by pushing the **CNCL softkey**.

## 2.4 Nearest and History Functions

### 2.4.1 Nearest Station Selection

The selection of nearest stations in ACD-57 requires GPS position data. Furthermore an installed station database (microSD card) is required. If no GPS position is available or no database is installed, the function is not available and the **NRST softkey** is not shown.

The nearest station list can be opened by pushing the **NRST softkey**. The **NRST softkey** is available on the channel selection page. In COM-only configuration, the **NRST softkey** is also available on the main page.

1. To open the channel selection page, push the **CHN softkey** on the main page.
2. To access the NEAREST station list, push the **NRST softkey**.
3. Use the **inner knob** to select a station.
4. Push the **inner knob pushbutton** to select the channel of the selected station and to exit the channel selection page to the main page.

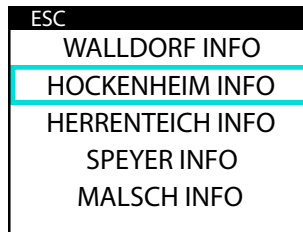

Figure 2.9.: NEAREST station list

You can exit the selection process, discard the selection, and return to the last page by pushing the **ESC softkey**.

## 2.4.2 Channel History

ACD-57 stores a history of selected channels in a recently-selected-channels list. Channels can be selected from this list.

The channel history list can be opened by pushing the **HIST softkey**. The **HIST softkey** is always available on the channel selection page. In COM-only configuration, the **HIST softkey** is also available on the main page.

1. To open the channel selection page, push the **CHN softkey** on the main page.
2. To access the history list, push the **HIST softkey**.
3. Use the **inner knob** to select a channel from the recently-selected-channels list.
4. Push the **inner knob pushbutton** to execute the channel selection and to exit the channel selection page to the main page.

ESC
118.275
123.650
129.975
118.150
119.800

Figure 2.10.: Channel History List

You can exit the selection process, discard the selection, and return to the last page by pushing the **ESC softkey**.

## 2.5 Channel Memory

ACD-57 features a user-configurable channel memory. Fifteen COM user channels can be saved including an optional text name/identifier.

### 2.5.1 Select a Channel from Memory

The channel memory list can be opened by pushing the **MEM softkey**. The **MEM softkey** is available on the channel selection page.

1. To open the channel selection page, push the **CHN softkey** on the main page.
2. To access the memory list, push the **MEM softkey** on the channel selection page.
3. Use the **inner knob** to select a position / identifier from the memory list.
4. Push the **inner knob pushbutton** to execute the selection and to exit to the main page.

ESC	EDIT	ADD	DEL
COMP 1			
SWEET HOME			
ATIS			
GROUND			
TEAM			

Figure 2.11.: Channel memory list

You can exit the selection process, discard the selection, and return to the last page by pushing the **ESC softkey**.

## 2.5.2 Store a Channel in Memory

1. To store a channel, enter the channel memory list and push the **ADD softkey**.
2. Select the desired channel using the **inner knob** (kHz) and **outer knob** (MHz). Push the **inner knob pushbutton** to execute the channel selection and to get to a text input page where you can enter an identifier for the stored channel.
3. Use the **outer knob** to select a position in the text and the **inner knob** to select a character. Push the **inner knob pushbutton** to execute the identifier text input and to store the channel to the memory list.

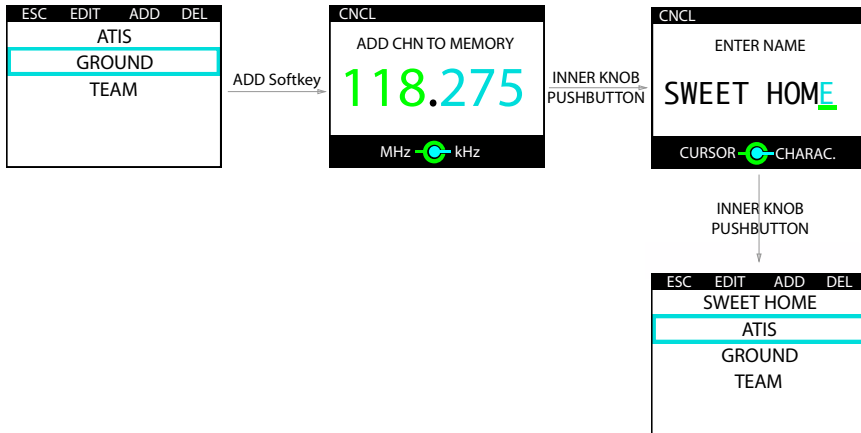

Figure 2.12.: Channel storing process in channel memory list

You can undo the storing process and return to the last page by pushing the **CNCL softkey**.

## 2.5.3 Editing a Stored Channel

1. To edit a stored channel, enter the channel memory list, use the **inner knob** to select a position/identifier, and push the **EDIT softkey** to edit the selected position/identifier.
2. Select the desired channel by using the **inner knob** (kHz) and **outer knob** (MHz). Push the **inner knob pushbutton** to execute the channel selection and to get to a text input page where you can edit the name for the stored channel.
3. Use the **outer knob** to select a position in the name and the **inner knob** to select a character. Push the **inner knob pushbutton** to execute the name selection and to store the channel in the memory list.



Figure 2.13.: Channel editing process in channel memory list

You can undo the selection/editing process and return to the main page by pushing the **CNCL softkey**.

### 2.5.4 Sorting the Channel Memory List

1. To sort the channel memory list, enter the channel memory list, use the **inner knob** to select a position/identifier that shall be repositioned in the list.
2. Push the **inner knob pushbutton**, hold and simultaneously rotate **inner knob** to move the position/identifier within the list.
3. Release the **inner knob pushbutton** as soon as the position/identifier is in the desired place in the list.

### 2.5.5 Deleting a Stored Channel

1. To delete a stored channel, enter the channel memory list, use the **inner knob** to select a position, and push the **DEL softkey** to delete the selected position.

The position is instantly deleted, there is no way to undo the process.

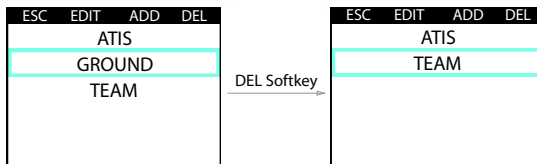

Figure 2.14.: Channel deletion process in channel memory list



## 2.6 RX/TX Indication and Stuck PTT Function

### 2.6.1 RX/TX Indication

The current receiver/transmitter status is shown on the main page. If radio messages are sent or received, a little indicator is shown.

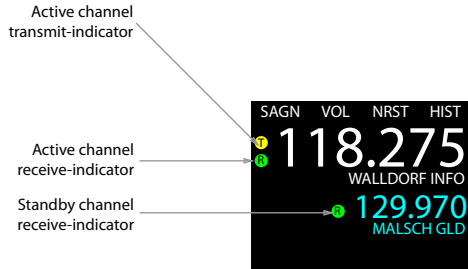

Figure 2.15.: RX and TX indicators explained

### 2.6.2 Last RX Indication

To indicate the channel on which the last transmission was received, a little indicator is shown next to that channel for a duration of 50 seconds after the end of the last incoming transmission or until another transmission is received.

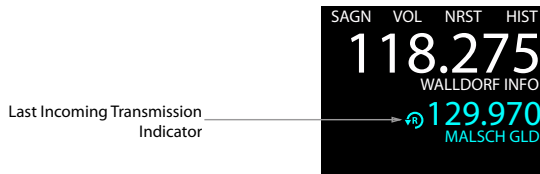

Figure 2.16.: Last RX indicator

### 2.6.3 Stuck PTT Indication

If the connected COM unit features a “stuck PTT detection” or a “stuck PTT timeout”, the status of a “stuck PTT” being detected is indicated on the main page by a crossed-out transmitter symbol as shown below or by an COM error message (depending on the type of the connected COM device).

STUCK PTT  
indicator



Figure 2.17.: Stuck PTT indicator

## 2.7 Say Again Function

If the connected COM unit features a recording or “say again”-function, the function is accessed through the **SAGN softkey** on the main page.

If the **SAGN softkey** on the main page is pushed (short push), the last recorded transmission is replayed. A replay indicator appears on the main page while the replay is active.

Replay Indicator

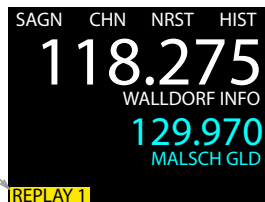

Figure 2.18.: **SAGN softkey** has been pushed, replay function is active

The replay can be interrupted by a received transmission. Actual transmissions normally have priority. This however depends on the setup of the connected COM system. Please inform yourself on ground about the configuration and behavior of the connected COM system before using the function in flight.

ACD-57 supports replay of several transmissions (depends on capacity of connected COM

system). By pushing the **SAGN softkey** again, you can replay earlier transmissions. The number on the replay indicator shows the current position.

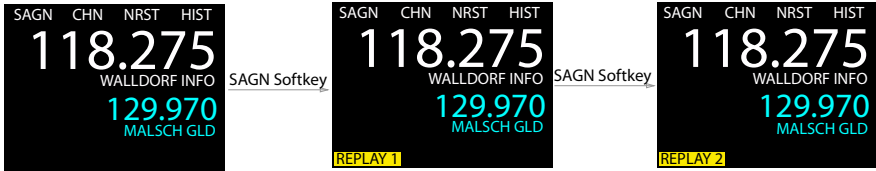

Figure 2.19.: **SAGN softkey** has been pushed, replay function is active and **SAGN softkey** is pushed again to replay an earlier transmission.

# 3

## XPDR Operation

### 3.1 Introduction

ACD-57 is capable of controlling a connected XPDR unit. ACD-57 can serve as primary means for control of a XPDR unit including XPDR unit setup, squawk code selection and mode control.

Multiple ACD-57 can be installed on one XPDR unit.

Familiarization of specific installation conditions in an aircraft, e.g. number of connected devices and topology is recommended before using ACD-57.

#### 3.1.1 XPDR user interface

Squawk code<sup>1</sup>, XPDR mode and transferred altitude (i.e. the altitude sent out by the connected XPDR system when replying) are displayed on the main page. Additionally a reply indicator shows if the transponder is currently replying to an interrogation.

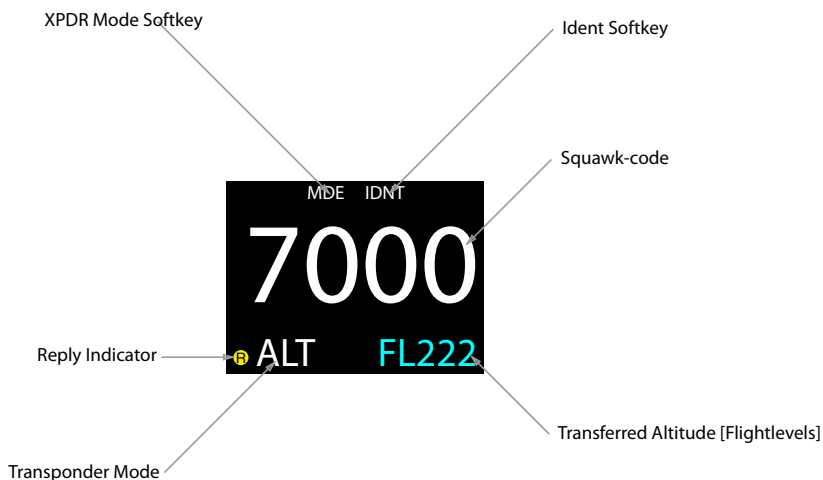

Figure 3.1.: XPDR user interface on Main Page

<sup>1</sup>“Squawk Code” here refers to the ATCRBS 4096 reply code. Details on the terminus “squawk” can be found here: [https://en.wikipedia.org/wiki/Transponder\\_\(aeronautics\)](https://en.wikipedia.org/wiki/Transponder_(aeronautics))

## 3.2 Selecting a Squawk Code

To enter the XPDR page, rotate the **inner knob** or the **outer knob** on the main page (in XPDR-only configuration) or push the **XPDR softkey** (in a configuration with VHF transceiver and XPDR).

1. on the main page, rotate the **inner knob** or push the **XPDR softkey** to enter the XPDR page.
2. Use the **outer knob** to select a position in the squawk code and use the **inner knob** to adjust the selected position's value.
3. Push the **inner knob pushbutton** to execute the selected squawk code and to exit to the main page.

Alternatively, you can use the **softkey 2** to toggle between the preset VFR squawk and the last non-VFR squawk. Then push the **inner knob pushbutton** to confirm the squawk code.

You can undo the squawk code selection and return to the main page by pushing the **CNCL softkey**

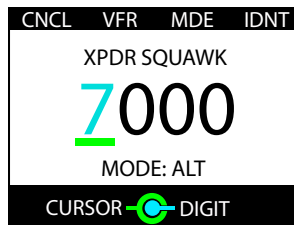

Figure 3.2.: XPDR page: Squawk code selection and other options for the transponder

## 3.3 Using the Ident Function

Push the **IDNT softkey** to initiate the ident function. This also confirms the currently selected squawk code. The **IDNT softkey** is always available on the XPDR page. In XPDR-only configuration, the **IDNT softkey** is also available on the main page.

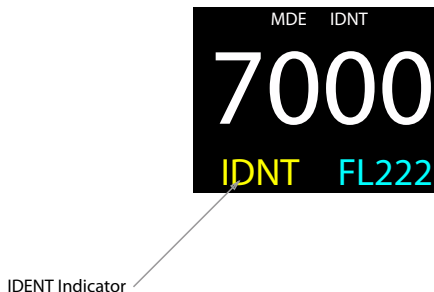

Figure 3.3.: Ident function is active. *IDNT* is shown instead of the normal mode indication as long as the ident feature is active.

## 3.4 Changing XPDR Mode

ACD-57 supports selection of the following XPDR Modes by the flight crew:

- SBY – XPDR is inactive. In this mode it does not draw power.
- ALT – Active Mode, also called “Altitude Mode”. This is the normal mode in flight.
- ON – Alt Inhibit Mode, no altitude data is transmitted.

### 3.4.1 Normal Mode Selection

A short push on the **MDE softkey** switches between SBY (Standby Mode) and ALT (Active Mode). It also confirms the currently selected squawk code. The **MDE softkey** is always available on the XPDR page. In XPDR-only configuration, the **MDE softkey** is also available on the main page.

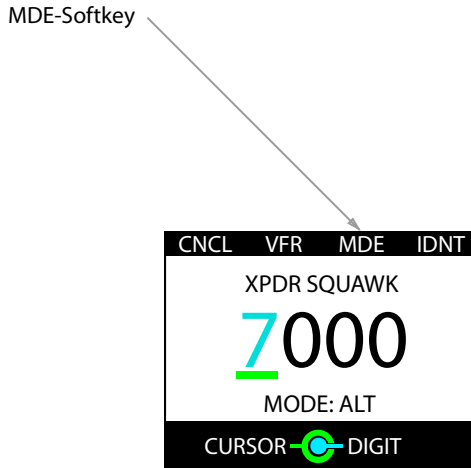

Figure 3.4.: MDE softkey on the XPDR page

### 3.4.2 Altitude Inhibit Mode

A long push on the MDE softkey switches to ON (ALT Inhibit Mode). In this mode, no altitude information is transmitted.

The use of this mode is only recommended if requested by air traffic control.

Another long push on the MDE softkey switches from ON (ALT Inhibit Mode) to SBY (Standby).

### 3.4.3 GND Mode

GND mode (All Call Inhibit Mode) is an optional, special XPDR mode that is automatically engaged if the aircraft is on ground. The installation and correct configuration of an On-Ground-Switch is required. To indicate this mode, a special GND flag is shown.

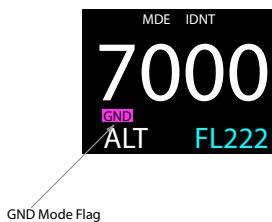

Figure 3.5.: GND mode flag. On-Ground-Switch is required. Due to regulatory requirements, GND mode can not be selected manually.



ACD-57 is capable of determining and displaying a precise pressure altitude and can be used as primary means of altimetry.

## 4.1 Altimeter User Interface

The current altitude is displayed numerically and with a tape-style indicator, or trend indicator. Depending on device configuration and other display content, the size of the altitude display may vary.

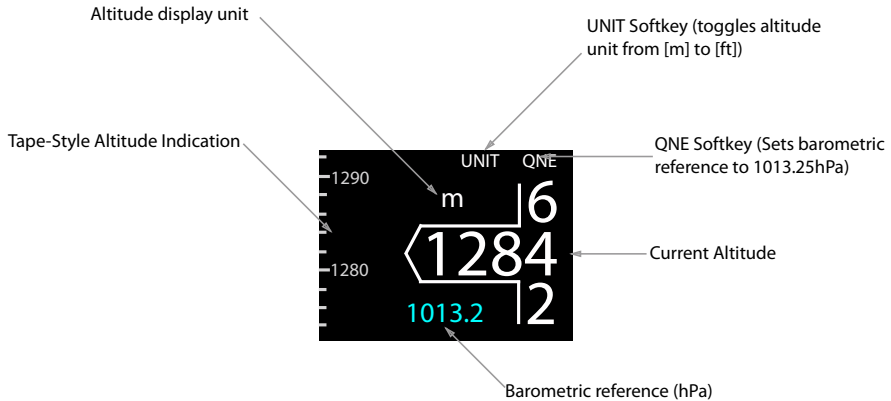

Figure 4.1.: Altimeter user interface

Units to display altitude and barometric pressure are user configurable. Altitude can be displayed in feet or meters, barometric pressure can be displayed in inches mercury or hectopascals (which equals millibars).

## 4.2 Adjusting Barometric Reference

To enter the barometric reference selection page, rotate the **inner knob** or the **outer knob** on the main page (In altimeter-only configuration) or push the **BARO softkey** (if additionally a VHF transceiver and/or a XPDR is controlled).

1. on the main page, rotate the **inner knob** or push the **BARO softkey** to enter the barometric reference selection page.
2. Use the **inner knob** and **outer knob** to adjust the current barometric reference.

3. Push the **inner knob pushbutton** to save the setting and to exit to the main page.

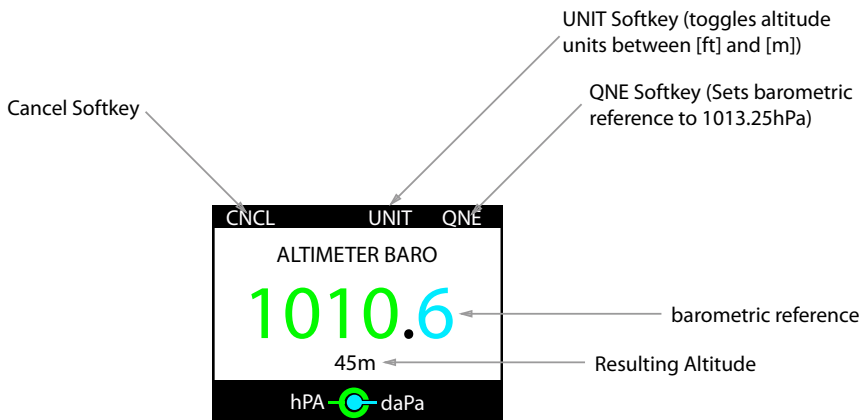

Figure 4.2.: Barometric reference selection page

The **QNE softkey** can be used to set the barometric reference to standard pressure (1013.25 hPa or 29.92 inHG). If the altimeter is already set to standard pressure, the **softkey 4** will instead show the last non-standard barometric reference, so that the pilot can quickly toggle between standard pressure and some other reference.

### 4.3 Altitude Display Unit

With the **UNIT softkey** it is possible to toggle quickly between feet and meters as altitude display unit.

ACD-57 can be used to control a VHF transceiver and an ATC Radar Beacon System (XPDR) at the same time. Additionally it can display altitude. Any combination of these three functions is possible and depends on configuration and connected subsystems.

## 5.1 COM, Transponder, and Altimeter Combined

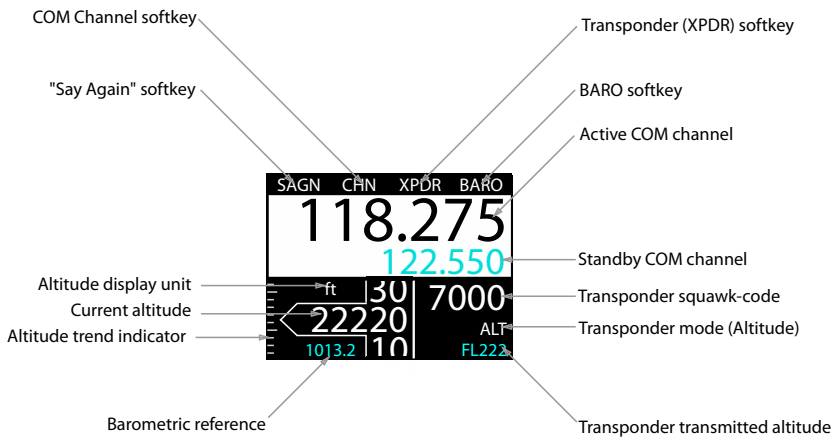

Figure 5.1.: User interface with COM, transponder, and altimeter functions combined.

## 5.2 COM and XPDR Combined

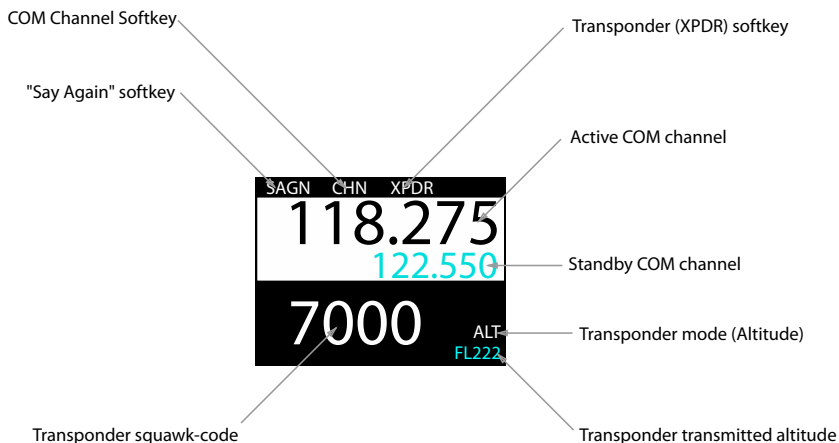

Figure 5.2.: User interface with COM and transponder functions combined.

## 5.3 COM and Altimeter Combined

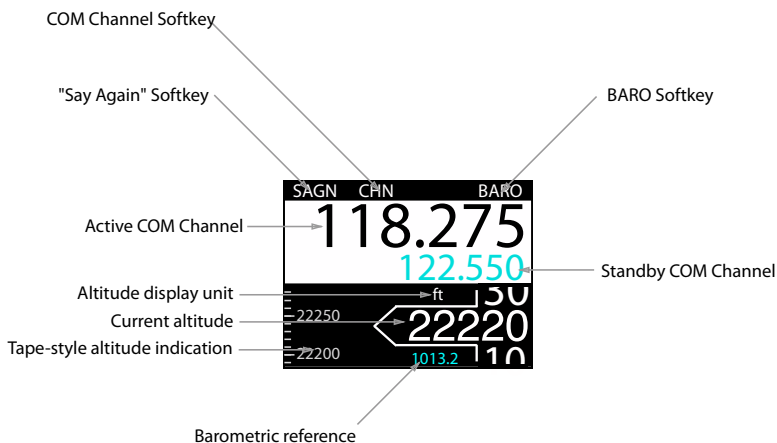

Figure 5.3.: User interface with COM and altimeter functions combined.

## 5.4 XPDR and Altimeter Combined

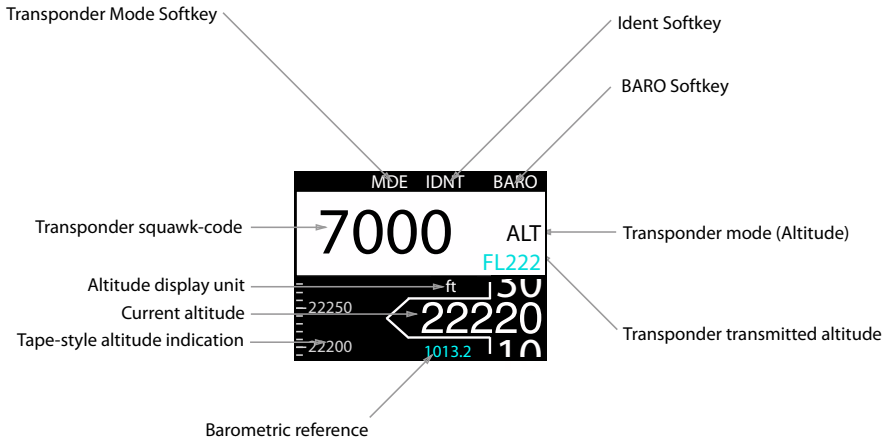

Figure 5.4.: User interface with transponder and altimeter functions combined.

# 6

## System Configuration

### 6.1 Configuration Operations

#### 6.1.1 Configuration Menu

ACD-57 is configured in the configuration menu. To enter the configuration menu, push the **inner knob pushbutton** for at least 2 seconds (long push). The menu contains several configuration options and informations about ACD-57 and connected systems.

Please find a menu diagram in appendix A

#### 6.1.2 Pin Code Protection

This manual contains only a few configurable parameters. These parameters are always accessible to the flight crew. The ACD-57 has many more configurable parameters and a large configuration menu. Due to safety reasons and regulatory requirements, not all configuration parameters are readily accessible. Many configuration menu levels require the entry of a pin code before they can be accessed. Pin codes can be entered in *CONFIGURATION MENU* → *PIN CODE*.

For a detailed overview of all configurable parameters and their recommended values, please consult the ACD-57 installation manual.

### 6.2 Device Configuration

In the configuration menu, *DEVICE* contains information about the ACD-57 device itself.

#### 6.2.1 Info

In the *DEVICE* menu, *INFO* contains specific information about the ACD-57 device such as hardware and software version information.

#### 6.2.2 Status

In the *DEVICE* menu, *STATUS* contains information about the power supply voltage, the position data source, and the pressure data source.

#### 6.2.3 Illumination Override

In the *DEVICE* menu, *ILLUMIN OVERRIDE* the current display and knob illumination level can be manually set.

Until the next restart of the ACD-57, this setting overrides the current illumination configu-

ration that has been entered during device installation. After a restart, the illumination configuration that has been entered during installation is restored.

To override the illumination configuration, please carry out the following steps:

1. Open the menu with a long push on the **inner knob pushbutton**.
2. Use the **inner knob** to navigate to *DEVICE* → *ILLUMIN OVERRIDE*
3. Once the illumination override page is entered, the illumination configuration is shown. Use the **inner knob** to override the illumination configuration and to enter a manual value.
4. Push the **inner knob pushbutton** to execute your selection.
5. Push the **ESC softkey** to leave the menu.

To reset the override and get back to the illumination configuration entered during installation, push the **RESET softkey**.

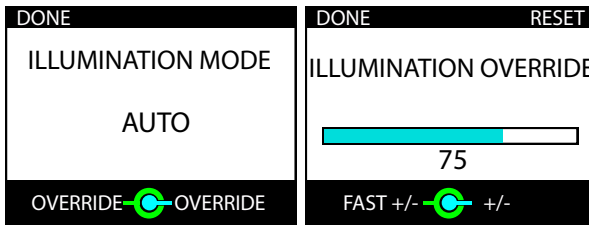

Figure 6.1.: Illumination override page. On the left the automatic illumination configuration is active, current illumination mode is shown. On the right the override is active.

## 6.3 Altimeter Configuration

The *ALTIMETER* menu section contains specific configuration parameters for the integrated altimeter.

### 6.3.1 Units

Units for altitude and pressure are user configurable.

- Altitude units configurable to meters or feet
- Pressure units configurable to hectopascals (millibars) or inches of mercury

The default settings are *meters* and *hectopascals*. To change the altimeter units configuration, please carry out the following steps:

1. Open the menu with a long push on the **inner knob pushbutton**.
2. Use the **inner knob** to navigate to *ALTIMETER* → *UNITS*.
3. Use the **inner knob** to navigate to a unit category, use the **inner knob pushbutton** to enter the menu.
4. Use the **inner knob** to select the desired unit.
5. Push the **inner knob pushbutton** to execute your selection.
6. Push the **ESC softkey** to leave the menu.



## 6.4 ACD-57 COM Control Configuration

The *COM CONTROL* menu section contains setup parameters for the control of a connected COM system.

### 6.4.1 Channel Spacing

The “channel spacing” setting selects which frequencies / channels can be dialed in by the ACD-57. With the default setting (*BOTH*) all 25 kHz frequencies and 8.33 kHz channels can be selected by either rotating the (inner knob) or simultaneously pushing the (inner knob pushbutton) and rotating the (inner knob) (25 kHz increments for faster adjustment).

Don't change this setting if you are not absolutely sure what you are doing. If your country uses 8.33 kHz channels, you will most likely still encounter stations with 25 kHz frequencies (like FIS). With those stations you might not hear their reply if you dial in the corresponding 8.33 kHz channel due to climax operation. If your country only uses 25 kHz frequencies, then set the spacing to 25kHz.

If the “channel spacing” is set to 25kHz or 8.3kHz, only the corresponding frequencies / channels can be dialed in. Note that for regular use you never want to set this to 8.3kHz.

To change the channel spacing configuration, please carry out the following steps:

1. Open the menu with a long push on the (inner knob pushbutton).
2. Use the (inner knob) to navigate to *COM CONTROL* → *INSTALLATION* → *CHN SPACING*.
3. Use the (inner knob) to select a desired spacing (*BOTH*, 25kHz, or 8.3kHz).
4. Push the (inner knob pushbutton) to execute your selection.
5. Push the (ESC softkey) to leave the menu.

### 6.4.2 Station Names

This parameter can be switched to *ON* in order to show station names on the main page of the COM user interface. If set to *OFF*, station names are not shown on the main page, but are still shown and used on other pages. The default setting for this parameter is *ON*.

The display of station names in ACD-57 requires GPS position data and an installed station database (microSD card). If no GPS position data or no station database is available, station names are not shown and position based radio channel selection is disabled.

Station names are only shown for stations within a distance of approx. 20 miles from the aircraft's current position.

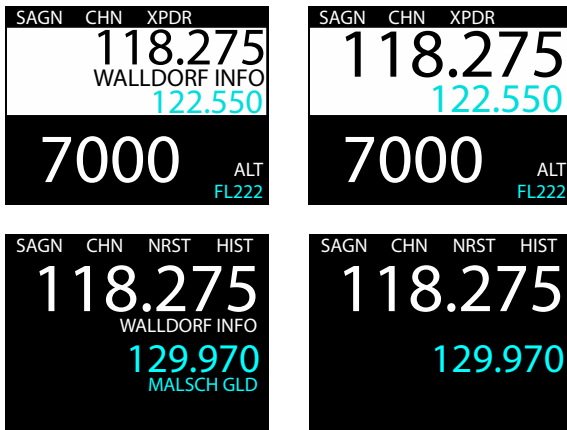

Figure 6.2.: COM main page with *STATION NAMES* parameter set to *ON* on the left and to *OFF* on the right. Please note that in COM only configuration, station names for both standby and active channel are shown. In all other configurations, only the active channel station name is shown.

To change this configuration, please carry out the following steps:

1. Open the menu with a long push on the **inner knob pushbutton**.
2. Use the **inner knob** to navigate to *COM CONTROL* → *STATION NAMES*.
3. Push the **inner knob pushbutton** to toggle between YES and NO.
4. Push the **ESC softkey** to leave the menu.

### 6.4.3 Knob Use

With this parameter the primary use of the **inner knob** and **outer knob** on the main page can be selected. The **inner knob pushbutton** function remains unaffected of this setting (always toggles active/standby channels). The default setting for this parameter is *VOLUME*.

It can be set to *VOLUME* in order to open the volume control page when turning the **inner knob** or the **outer knob**. In this case **softkey 2** will have the function to open the channel selection page.

It can also be set to *CHANNEL* in order to open the channel selection page when turning the **inner knob** or the **outer knob**. In this case **softkey 2** will have the function to open the volume control page.

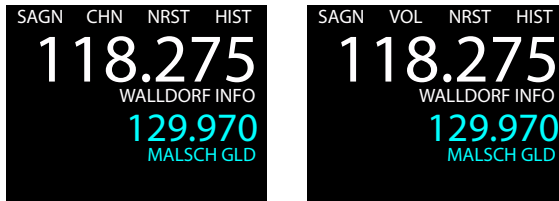

Figure 6.3.: COM main page with *KNOB USE* parameter set to *VOLUME* on the left and to *CHANNEL* on the right.

In aircraft with no audio panel or intercom, we recommend to use the default setting (*KNOB USE* set to *VOLUME*). If an audio panel/intercom is used, it may not be required to change COM volume frequently. In this case, setting the *KNOB USE* parameter to *CHANNEL* is recommended for easier channel selection.

To change the knob use configuration, please carry out the following steps:

1. Open the menu with a long push on the **inner knob pushbutton**.
2. Use the **inner knob** to navigate to *COM CONTROL* → *KNOB USE*.
3. Use the **inner knob** to select a desired option (*VOLUME* or *CHANNEL*).
4. Push the **inner knob pushbutton** to execute your selection.
5. Push the **ESC softkey** to leave the menu.

## 6.5 Connected COM System Configuration

The *COM SYSTEM* section contains setup parameters for a connected VHF transceiver. Depending on the type of connected VHF transceiver, different parameters are available. Where possible, menu parameter names are consistent to parameter names in the VHF transceiver's documentation.

Please note in dual ACD-57 installations that if a Becker 620X, TRIGTY9x, or Dittel/TQKRT2 is controlled, the *COM SYSTEM* menu section is only available on the display the VHF transceiver is directly connected to.

Please consult the VHF transceiver's documentation for details on parameters and recommended values.

## 6.6 ACD-57 XPDR Control Configuration

The *XPDR CONTROL* section contains setup parameters for the control of a connected XPDR system.

### 6.6.1 VFR Preset

Here a preset value for the VFR squawk code can be entered. This value is used when the *VFR Softkey* is pressed on the XPDR page.

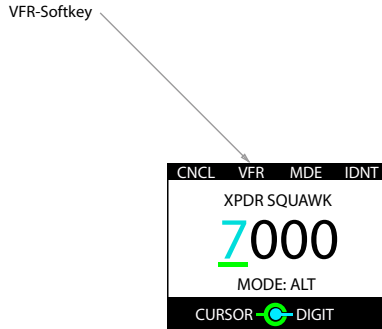

Figure 6.4.: **VFR softkey** on the XPDR page. The squawk code entered in the *VFR PRESET* parameter is set if the softkey is pushed.

To change the VFR squawk code preset, please carry out the following steps:

1. Open the menu with a long push on the **inner knob pushbutton**.
2. Use the **inner knob** to navigate to *XPDR CONTROL* → *VFR PRESET*.
3. Use the **outer knob** to select a position/digit and the **inner knob** to change the value at this position.
4. Push the **inner knob pushbutton** to execute your selection.
5. Push the **ESC softkey** to leave the menu.

## 6.7 Connected XPDR System Configuration

The *XPDR SYSTEM* section contains setup parameters for a connected XPDR system. Please consult the XPDR system's documentation for details on parameters and recommended values.

Note that for the VT-01, the system state, software versions, and configuration is not known to the ACD-57 unless the VT-01 has been set to ALT mode at least once during the runtime of the ACD-57.

Please note in dual ACD-57 installations that if a TRIG TT2x is controlled, the *XPDR SYSTEM* menu section is only available on the display the transponder is directly connected to.

### 6.7.1 Flight ID

In this menu, a flight ID can be entered. The flight ID must correspond to the aircraft identification specified in item 7 of the ICAO flight plan, or, when no flight plan has been filed, the aircraft registration.

To enter a flight ID, please carry out the following steps:

1. Open the menu with a long push on the **inner knob pushbutton**.
2. Use the **inner knob** to navigate to *XPDR SYSTEM* → *FLIGHT ID*.
3. Use the **outer knob** to select a position/digit and the **inner knob** to change the value at this position.
4. Push the **inner knob pushbutton** to execute your selection.
5. Push the **ESC softkey** to leave the menu.

## 7.1 Version Identification

The software version can be reviewed in *CONFIGURATION MENU* → *DEVICE* → *INFO*.

## 7.2 Software/Database Loading

Software updates and the station database are loaded using the integrated microSD card slot and a microSD memory card.

While the software is actually loaded onto the device, the station database remains on the microSD card. Therefore database information is only accessible if the microSD card is installed.

If the microSD card is not installed, database functions will not be available.

Never remove the microSD card while the device is in operation. If the microSD card is removed from the device during runtime, the device's software may stop working. In this case a system restart would be required.

### 7.2.1 microSD Card Slot

A microSD card slot is located on the right side of the unit's front panel. A microSD memory card can be inserted and removed from the device.

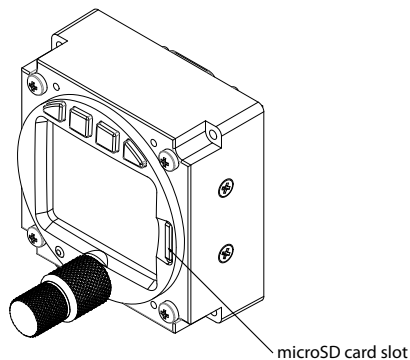

Figure 7.1.: microSD Card Slot

To insert a microSD card, insert the card into the slot, print facing to the display, little nose facing upwards and gently push the card until it clicks in.

Inserting the microSD card in the wrong orientation may damage the slot.

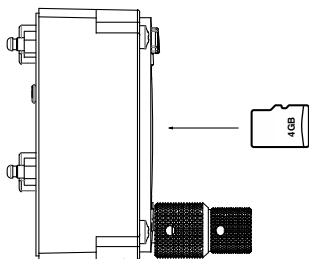

Figure 7.2.: microSD card in correct orientation

To remove an inserted microSD card, use your fingernail to gently push on the card until a click is audible. The card will be released following the click. Use your fingernail to remove the card.

Be careful. Application of too much force may damage the slot.

ACD-57 is compatible to all FAT or FAT32 formatted microSD cards. It has been successfully tested with microSD cards with a storage size of 2 to 64 gigabytes.

## 7.2.2 Using a Station Database

To use a database, please carry out the following steps:

1. Purchase a valid station database file in the *AIR Avionics License Store*. Please visit <https://www.air-avionics.com/license> for details.
2. Load the station database file onto a microSD card.
3. Insert the microSD card into the ACD-57.
4. Power the unit on.
5. Open the menu with a long push on the **inner knob pushbutton**.
6. Use the **inner knob** to navigate to *CONFIGURATION MENU* → *DEVICE* → *INFO* → *DATABASES*.
7. Verify correct installation in the databases list.
8. Push the **ESC softkey** to leave the menu.



When the database license expires, the database can no longer be used and database functions are no longer available.

The station database and related functions are only available while the microSD card holding the station database file is inserted. If the microSD card is removed, the database and all related functions are unavailable.

### 7.2.3 Loading Software to ACD-57

For details on loading new software onto ACD-57, please consult the ACD-57 Installation Manual [?].

ACD-57 features a range of built-in self test features that continuously monitor system state and the state of connected systems to detect failures.

## 8.1 Failures

The detection of a failure is always annunciated to the flight crew on the display.

Depending on detected failure and failure severity, the system may seize to function or functionality may be limited. Failure messages either close automatically, can be closed by the flight crew, or can not be closed at all depending on failure severity.



Figure 8.1.: Major internal failure annunciation

## 8.2 Insufficient Data Failure Modes

### 8.2.1 No data from connected systems or internal systems

ACD-57 continuously monitors data from connected systems or its own internal hardware and software systems. If data is not regularly updated, it is no longer displayed. Instead the corresponding value is "crossed out" by a red cross (in case of entire systems that fail to respond) or yellow crosses (if single datasets in the menu expire).

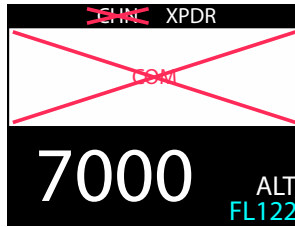

Figure 8.2.: No data/communication with connected COM system.

### 8.2.2 No GPS Data and/or No Database Installed

Some functions require a Database on an inserted microSD memory card and valid GPS position data. These are:

- Display of station names on the main page or the channel selection page.
- Nearest station list functions

If no GPS position data or database is available, station names are not displayed on the main page or the channel selection page. If trying to access the nearest station list by pushing the **NRST softkey**, an information message appears indicating that this function is not available. The message can be acknowledged by pushing the **inner knob pushbutton**.

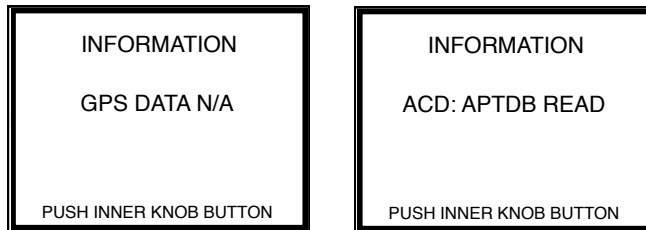

Figure 8.3.: Message indicating that database is not available (right) and GPS data is not available (left)

## 8.3 Systems Failures

### 8.3.1 Failure Condition Classification

Depending on failure severity and its consequences for the operational state of the system, ACD-57 distinguishes between two following failure classifications:

- Fatal Failure
- Reduced Function Failure

### 8.3.2 Fatal Failures

In case of a fatal failure, the failed system has seized operation. This can not be recovered during runtime, a restart is required.

A fatal failure message is displayed in *red* color and will remain visible for the rest of the runtime of the system.

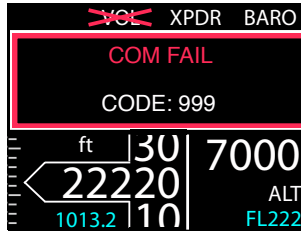

Figure 8.4.: Connected COM system has detected a fatal failure, failure code is displayed. Unaffected systems remain functional.

### 8.3.3 Reduced Function Failures

In case of a reduced function failure, the failed system has an issue and functionality is limited/reduced. Some functions of the system may still be available.

A reduced function failure message is displayed in *amber* color and will disappear within 5 seconds. After that, the failed system will be framed by an *amber* rectangle.

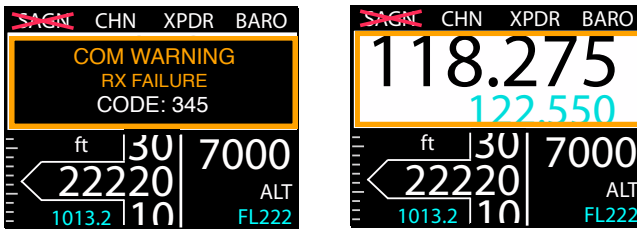

Figure 8.5.: Reduced function failure message (left) and system with reduced function after failure message has disappeared (right)

### 8.3.4 Failure Codes

Whenever available, failure codes are shown. All current failure codes and overall system state can be reviewed in *CONFIGURATION MENU* → *FAILURES*.

For failure code identification, please consult the manual of the affected system

## 9.1 I am unable to tune in 8.33 kHz channels

In its recommended standard setup, *CONFIGURATION MENU* → *COM CONTROL* → *CHN SPACING* is set to *BOTH*.

In earlier software versions, with this setting, you can tune 25 kHz frequencies by turning the (inner knob). To tune 8.33 kHz channel, push the (inner knob pushbutton) while simultaneously rotating the (inner knob). Like this, you can tune quickly in 25 kHz steps as before with old radios, yet the push-turn gesture allows you to fine-tune 8.33 kHz steps conveniently.

Newer software versions (0.44 and later) show a different behavior: You can tune all channels by turning the (inner knob). Push the (inner knob pushbutton) while simultaneously rotating the (inner knob) to tune channels or frequencies in the 25 kHz steps and, therefore, quicker.

## 9.2 I am unable to tune in 25 kHz frequencies

In its recommended standard setup, *CONFIGURATION MENU* → *COM CONTROL* → *CHN SPACING* is set to *BOTH*. If set to *8.3kHz*, 25 kHz frequencies are not tunable.

Please go to *CONFIGURATION MENU* → *COM CONTROL* → *CHN SPACING* and set this parameter to *BOTH*.

# A

## Configuration Menu Diagram

This menu diagram only shows the basic configuration parameters accessible to the flight crew. For a complete menu diagram including all pin code protected parameters, please consult the ACD-57 Installation Manual [?].

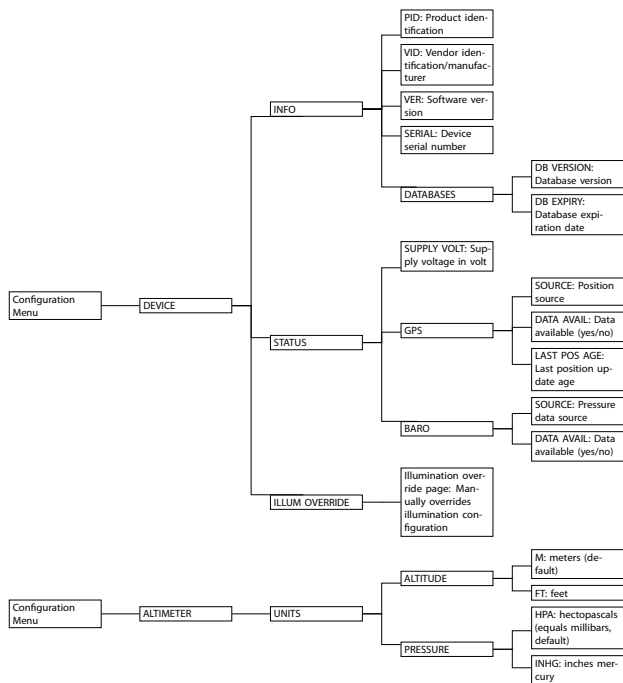

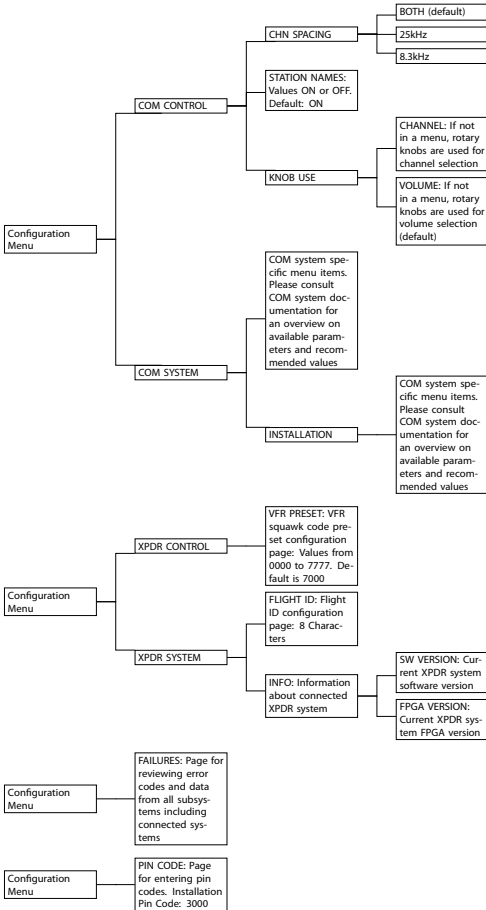

# B

## Softkey Menu Diagram

### B.1 COM Control Only Softkeys

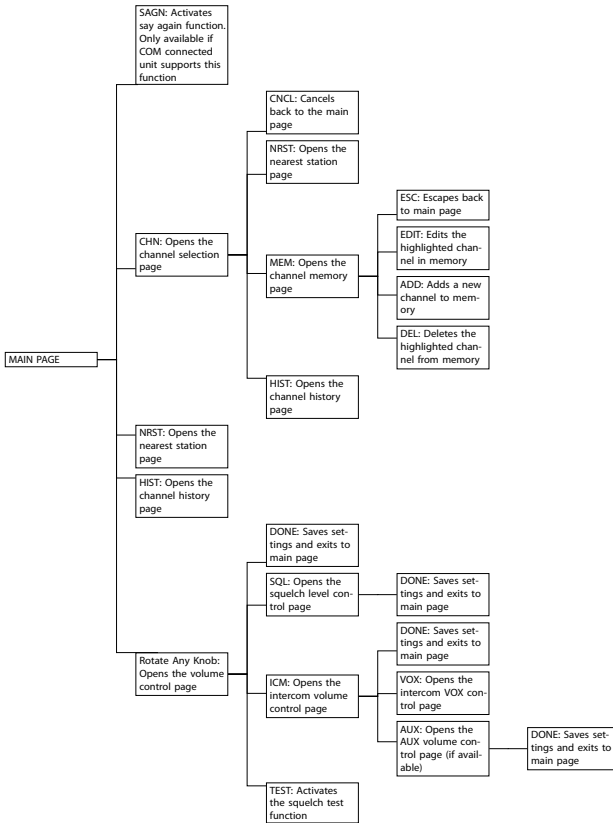

Please note that depending on the setup of the *KNOB USE* parameter, the **CHN softkey** on the main page may be replaced by a **VOL softkey** (volume control) and rotation of **inner knob** or **outer knob** will open the channel selection page.



## B.2 XPDR Control Only Softkeys

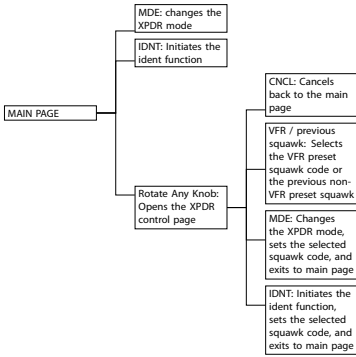

## B.3 Altimeter Only Softkeys

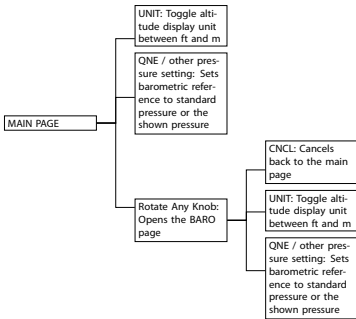

## B.4 COM and XPDR Control Softkeys

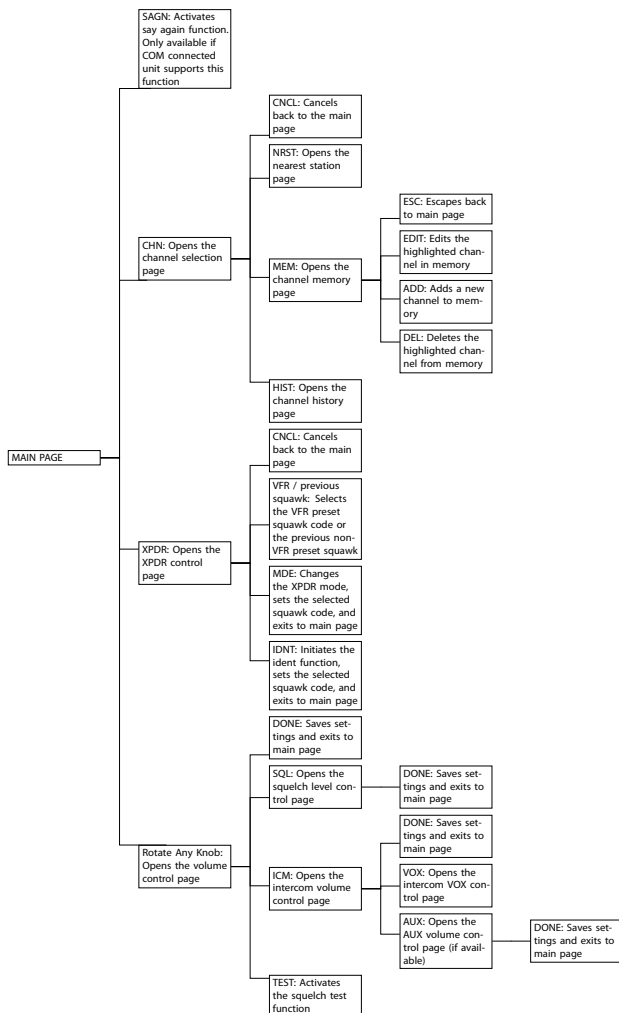

Please note that depending on the setup of the *Knob Use* parameter, the **CHN** softkey on the main page may be replaced by a **VOL** softkey (volume control) and rotation of inner knob or outer knob will open the channel selection page.

## B.5 COM and Altimeter Control Softkeys

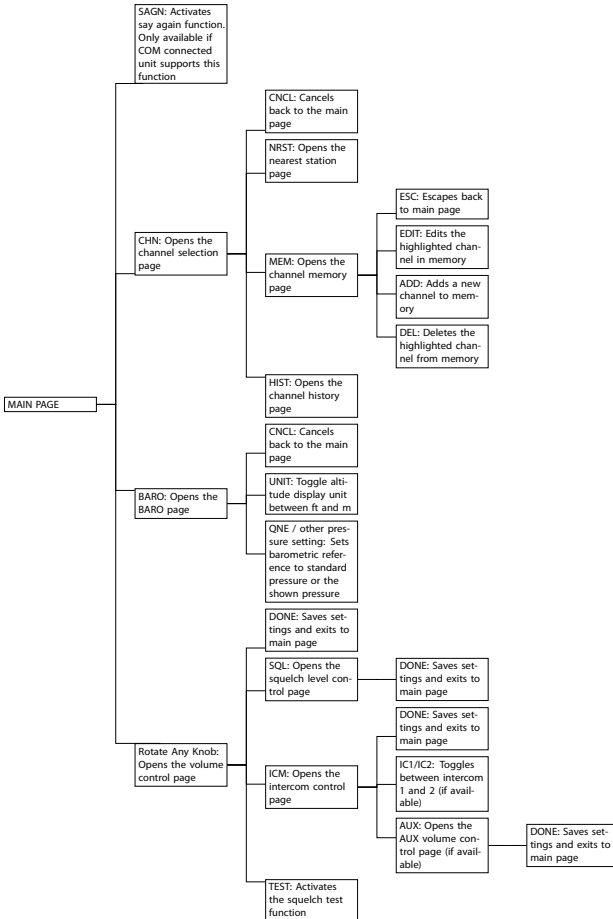

Please note that depending on the setup of the *KNOB USE* parameter, the **CHN softkey** on the main page may be replaced by a **VOL softkey** (volume control) and rotation of **inner knob** or **outer knob** will open the channel selection page.

## B.6 XPDR Control and Altimeter Softkeys

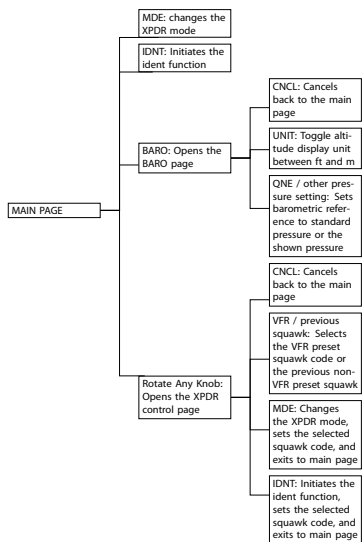

## B.7 COM, XPDR Control, and Altimeter Softkeys

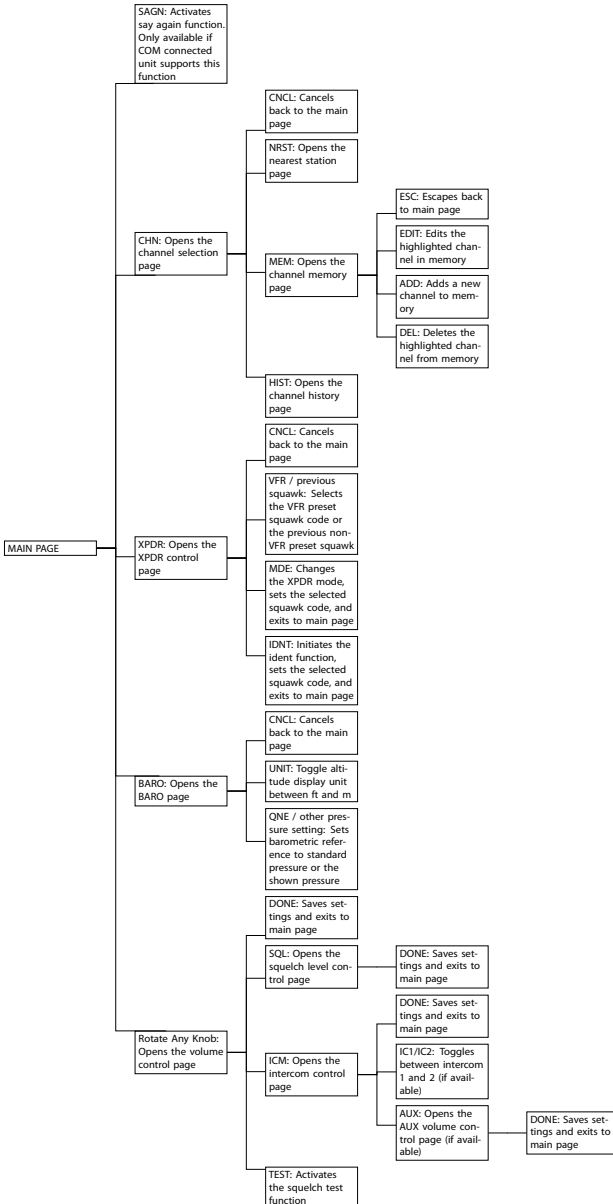

Please note that depending on the setup of the *KNOB USE* parameter, the **CHN** softkey on the main page may be replaced by a **VOL** softkey (volume control) and rotation of **inner knob** or **outer knob** will open the channel selection page.

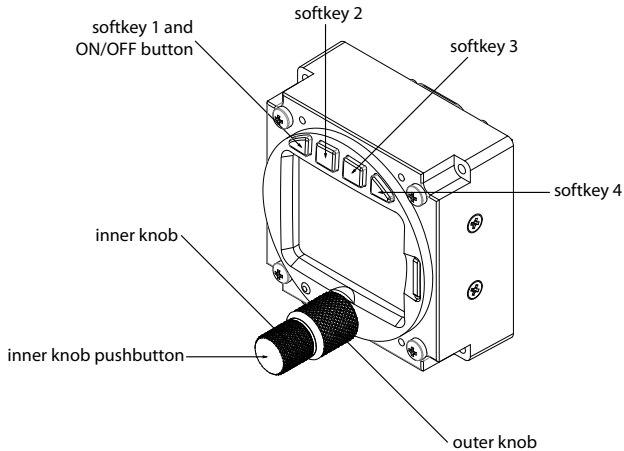

Figure C.1.: ACD-57 pilot controls

## C.1 Switch On or Off

If not switching on automatically, push **softkey 1**, the leftmost button on top of the display, to switch the unit on. To switch the unit off, push **softkey 1** longer than 4 seconds.

## C.2 COM Operation

### C.2.1 Volume Control

On the main page, the **inner knob** opens the volume control page. On the volume control page, the **inner knob** controls the ACTIVE channel volume, the **outer knob** controls the STANDBY channel volume.

### C.2.2 Channel Selection

On the main page, a short push on the **CHN softkey** opens the channel selection page. On the channel selection page, the **inner knob** controls the kHz, the **outer knob** controls the MHz.

To select 8.33 kHz channels, push and turn the **inner knob**.

## C.3 XPDR Operation

### C.3.1 Squawk Code Entry

The squawk code is entered in the XPDR page. The XPDR page is opened by pushing the **XPDR softkey** on the main page. On the XPDR page, use the **outer knob** to select a position in the squawk code and use the **inner knob** to adjust the selected position's value. Push the **inner knob pushbutton** to confirm the squawk code.

### C.3.2 XPDR Mode Change

To change the XPDR mode from SBY (Standby) to ALT (Active) or back, please push the **MDE softkey** on the XPDR page. This also confirms the currently selected squawk code.

### C.3.3 XPDR Ident Function

To use the XPDR ident function, please push the **IDNT softkey** on the XPDR page. This also confirms the currently selected squawk code.

## C.4 Altimeter Operation

To adjust the barometric reference, please push the **BARO softkey** on the main page. On the baro input page, use the **outer knob** to adjust hPa and the **inner knob** to adjust daPa. Push the **QNE softkey** to use standard pressure.

To toggle between feet and meters, use the **UNIT softkey**.